

**AMPLIFIED
ENGINEERING**

node MINI

USER MANUAL

EDITION :
April 2026



Multi-protocol data collecting, buffering, packaging, inferencing & sending (to cloud or server) - in one rugged, compact device

MULTI PROTOCOL::

CAN FD/ J1939/ OBD2 |
Modbus TCP/ RTU |
Serial RS485 | Digital I/O |
WiFi | Bluetooth | Ethernet

4G CONNECTIVITY OPTION

Suitable for remote or mobile type of assets.

CLOUD CLIENTS::

Simply authenticate to publish to AWS, Azure, Google Cloud, Ubidots or MQTT endpoints.

EDGE COMPUTE::

Run scripts using our Python/LUA API libraries; or Containers & Node Red on Debian 11OS.

TABLE OF CONTENTS

SAFETY OF USE	3
SECTION 1: ABOUT	
1.1 nodeMINI Specifications	4
1.2 Board Interface	7
1.3 I/O & Ports	10
1.4 Remote Power CNTL Input	13
SECTION 2: SETTING UP	
2.1 SIM Installation	14
2.2 Logging In	15
SECTION 3: CONFIGURATIONS	
3.1 Quickstart Guide	16
3.2 WAN & Cellular Settings	17
3.3 Dynamic DNS	18
3.4 Ethernet Settings	19
3.5 Wireless Settings	20
3.6 Serial, CAN & I/O Settings	21
3.7 IoT Hardware	22
3.8 IoT Client	24
3.9 Management	26
3.10 System Status	29
CONTACT US	30



SAFETY OF USE

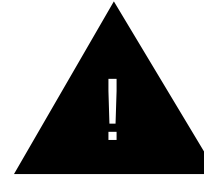

ALL CONDITIONS

All specialist electronic devices must be operated with due care to avoid damage or injuries and should be installed and operated by a trained personnel. The Recommended Operating Conditions are as follows:

Parameter	Min	Typ	Max	Unit
Main Power Supply voltage	9.6	12-24	28.8	V

DO NOT OPERATE THIS EQUIPMENT IN ENVIRONMENTS CONTAINING POTENTIALLY EXPLOSIVE GASES OR LIQUIDS, EXAMPLE, GAS STATIONS AND CHEMICAL PLANTS AND EXPLOSIVE STORES.

POWER SETUP

Inadequate current or dips in voltage may cause the device to fail to connect to data services even if the LEDs are lighted up. The Absolute Maximum Ratings for the device is as follows:

Parameter	Min	Max	Unit
Main Power Supply voltage	-0.3	32	V

STRESS BEYOND THE ABSOLUTE MAXIMUM RATINGS MAY CAUSE PERMANENT DAMAGE TO THE DEVICE.

SIM CARD

Never remove or insert SIM card when device has PWR switched in "ON" position. Damage caused to device or SIM in such case will not be warranted.

CONFIGURING THE ROUTER

Do not reboot/power-down the device until the writing process is acknowledged as completed.

ABOUT

1.1 nodeMINI SPECIFICATIONS

* denotes features that may be model specific

NOTE:
WiFi & Bluetooth features is mutually exclusive with the GPS option on the nodeMINI

CPU CORE

CPU NXP i.MX9352 dual-core ARM Cortex-A55, 1.7GHz

REAL TIME CO-PROCESSOR ARM Cortex-M33, 250Mhz

STORAGE & MEMORY

RAM 2GB LPDDR4

Storage 32GB eMMC flash

NETWORKING

LAN 1x Gbit Ethernet ports, RJ45

WiFi* 802.11ax WiFi 6

BLE* Bluetooth 5.4 BLE

CELLULAR* 4G/LTE CAT4 cellular module, Telit LE910 Worldwide LTE, UMTS/HSPA

GNSS* GPS (mutually exclusive with WiFi/Bluetooth)

REAL TIME CLOCK (RTC)

· Real time clock operated from on-board coin-cell battery

INDICATORS

· 1 x programmable dual-colour LEDs
· 1 x power LED

ELECTRICAL & MECHANICAL

POWER SUPPLY & CONSUMPTION · 12V-24V DC (-20%/+20%)
Reverse voltage protection
· 1-5W depending on system

HOUSING DESIGN · Aluminium

COOLING · Passive cooling, fanless design

DIMENSIONS · Gateway - 83 x 28 x 55 mm

WEIGHT · 170g

ENVIRONMENTAL & RELIABILITY

MTTF · > 200,000 hours

OPERATION TEMPERATURE · Commercial version: 0 to 60 degree celsius
· Industrial version: -40 to 80 degree celsius

STORAGE TEMPERATURE · -40 to 85 degree celsius

RELATIVE HUMIDITY · Operation: 10% to 90%
· Storage: 5% to 95%

WARRANTY

· 5 year manufacturer warranty

ABOUT

1. 1 nodeMINI SPECIFICATIONS

* denotes features that may be model specific

FIRMWARE FEATURES

GATEWAY MANAGEMENT

- Integrated Web Menu Configuration
- SSH for Remote LINUX Management

SUPPORTED PROTOCOLS

- CAN Bus J1939/FD/OBD2
- Modbus TCP/RTU
- Serial RS485/232
- WiFi*
- Bluetooth BLE 5.4*

CLOUD/ SERVER CONNECTIONS

- MQTT Client with TLS Security
- AWS IoT Core / Sitewise Client
- Azure IoT Hub Client
- Ubidots Client
- Google Cloud Client

NETWORKING

- Dynamic DNS

NETWORK ROBUSTNESS

- Designed for maximum uptime from available network
- NetMgr WWAN connect timeouts
- End-to-End PING connectivity testing with reboot

INTEGRATED DATA FEATURES

- Accessible SQL Table + Scripts
- FIFO buffer data mode config
- Real Time data mode config

USER CUSTOM PROGRAMMING

- Docker & Node Red deployments on Debian OS
- API libraries: Python (2.7.15 & 3.6.5)/ LUA/ BASH

SECURITY

- Secure boot, implemented with i.MX93 AHAB module
- TPM 2.0, Infineon SLB9673

WATCHDOG

- Hardware watchdog

POE

- Optional support for PoE (powered device)

POWER MODES

ON All internal power rails are enabled. Mode entered automatically when the main power supply is connected.

OFF CPU core power rails are off. All peripheral power rails are off.

SLEEP DRAM is maintained in self-refresh. Most CPU core power rails are off. Most of the peripheral power rails are off.

ABOUT

1. 1 nodeMINI SPECIFICATIONS

* denotes features that may be model specific

GATEWAY I/O

USB	1x USB2.0 type-C connector
RS485	1x RS485, 2-wire port, Isolated, terminal-block connector
CAN BUS	1x CAN-FD port
Digital I/O*	Optional 3x digital outputs + 3x digital inputs, Isolated, compliant with EN 61131-2, terminal-block connector
Debug	1x serial console via UART-to-USB bridge, micro-USB connector.

TERMINAL BLOCK CONNECTORS

- 0.2 - 1.5mm²
- 16 - 26 AWG

IN THE BOX

- 1 x nodeMINI gateway

OPTIONAL ACCESSORIES

- Power supply unit
- High-gain outdoor antenna (wall mounted)
- High-gain outdoor antenna (pole mounted)
- 2x 2.4GHz / 5GHz WiFi BLE Antennas
- Active GPS antenna

ABOUT

Figure 1: Front Panel Layout

1.2 BOARD INTERFACE - FRONT PANEL

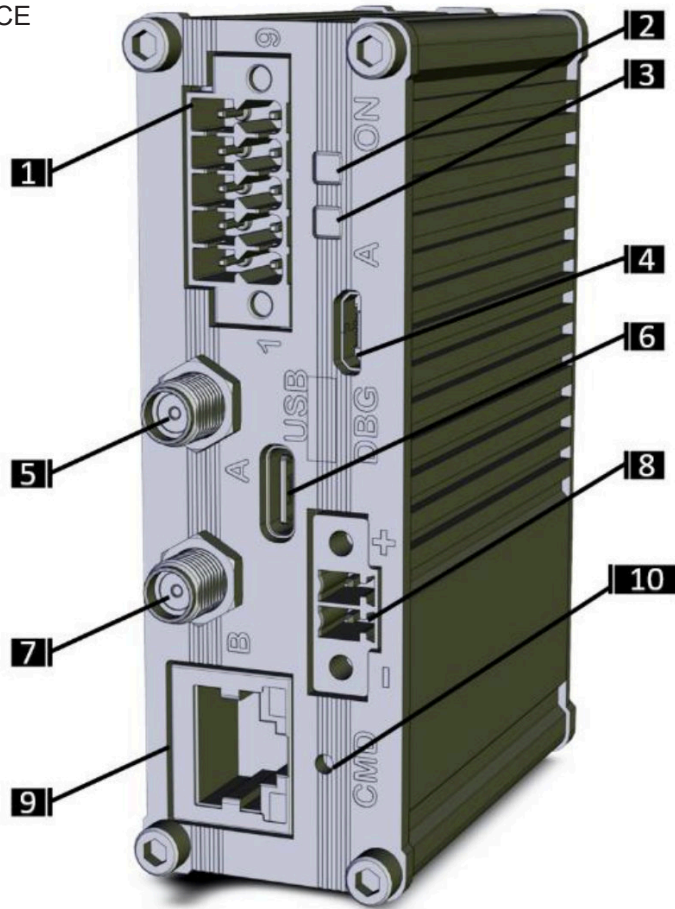

FRONT PANEL LAYOUT

Item	Description
1	Industrial I/O terminal block, 10 pin, 16-26 AWG
2	System status indicator. Dual-color blue/amber LED
3	User programmable LED A
4	Console connector, micro-USB type
5	Antenna connector A
6	USB connector
7	Antenna connector B
8	DC power input connector
9	Ethernet port, dual RJ45 connector
10	User programmable recessed push-button

Table 1: Front Panel Layout

SYSTEM STATUS INDICATOR LED

LED State	Gateway Status
OFF	System is in OFF or deep-sleep state
Solid BLUE	System is running U-boot bootloader
Solid AMBER	U-boot bootloader is not running. Indicates bootloader corruption
Blinking BLUE	System is running Linux O/S. Normal operation mode

Table 2: System Status Indicators

ABOUT

1. 2 BOARD INTERFACE - BACK PANEL

Figure 2: Back Panel Layout

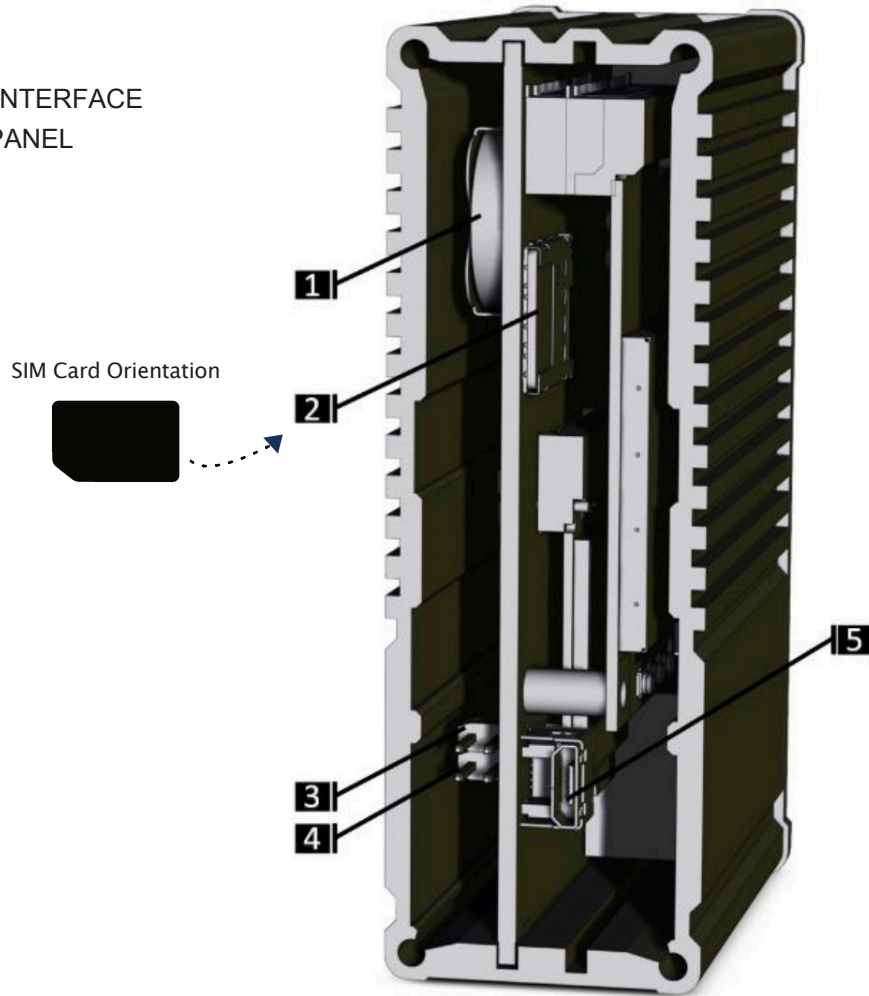

BACK PANEL LAYOUT

Item	Description
1	RTC battery holder
2	SIM card socket
3,4	RS485 / CAN bus termination jumpers
5	SDP programming port, micro-USB type

Table 3: Back Panel Layout

ABOUT

1.2

BOARD INTERFACE - POWER INPUT CONNECTOR

Warning:

Connecting the Remote Power Button input to DC voltage may damage the device.

Only connect the input pin to GND via contact switch.

Connector type:

4-pin dual row plug with screw terminal connections.

Locking: screw flange

Pitch: 3.5mm

Wire cross-section: AWG16
- AWG26

Connector P/N:
JL15EDGVM-35004G0[1/2]

Mating Connector P/N:
JiNL JL15EDGKM-35004G01

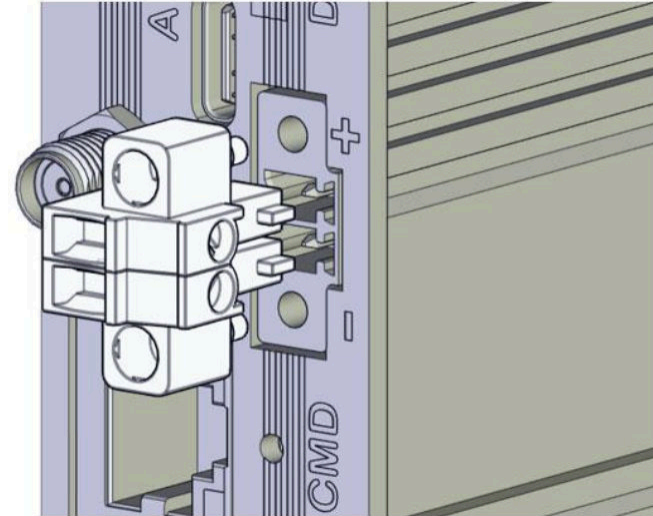

Figure 3:
Power Input Connector

POWER CONNECTOR PINOUT

Pin	Signal Name	Description
1	+V	V+ DC pin
2	V-	V0 DC pin

Table 4: Power Connector Pinout

ABOUT

1. 3

I/O & PORTS

CAN Bus

The nodeMINI CAN FD port is implemented with i.MX93 CAN controller with the following characteristics:

- Key characteristics:
- Full implementation of the CAN FD protocol & CAN protocol specification 2.0B
 - Compliant with the ISO 11898-1 Standard
 - Optional 120 Ω termination resistor controlled by jumpers located behind the back panel (see page 10).

RS485

RS485 function is implemented with MAX13488 transceiver interfaced with i.MX93 Plus UART port.

- Key characteristics:
- 2-wire, half duplex
 - Galvanic isolation from main unit
 - Programmable baud rate of up to 3Mbps
 - Optional 120 Ω termination resistors controlled by jumpers located behind the back panel

Ethernet

The nodeMINI incorporates one Gigabit Ethernet port implemented with i.MX93 internal MAC and Realtek RTL8211 PHY.

USB Host Connector

The nodeMINI USB2.0 host port is available through standard type-C USB connector.

USB2.0 port is multiplexed with wireless mesh modules.

Note: The nodeMINI USB port does not provide USB3.0 functionality

Note: When the nodeMINI is assembled with a wireless mesh module, USB host connector is inactive and cannot be used

ABOUT

INDUSTRIAL I/O CONNECTOR

The industrial I/O connector is a 10-pin dual-row terminal block. The connector pin out is shown below.

1. 3 I/O & PORTS

Connector details:

Locking: screw flange

Pitch: 3.5mm

Connector P/N: JiLN
JL15EDGRHCM-35005B01

Mating Connector P/N:
JiLN JL15EDGKNHM-35016B01

Pin	Signal Name	Description
1	DIO_VIN	Digital I/O external DC power input
2	DIO_1	Digital input 1 / output 1
3	DIO_2	Digital input 2 / output 2
4	DIO_3	Digital input 3 / output 3
5	PORTA_POS	PORT-A: RS485 positive / CAN high
6	PORTA_NEG	PORT-A: RS485 negative / CAN low
7	PORTB_POS	PORT-B: RS485 positive / CAN high
8	PORTB_NEG	PORT-B: RS485 negative / CAN low
9	GND	Common ground
10	CNTL	Programmable power control

Table 7: Industrial I/O Connector

Figure 4: Industrial I/O Connector

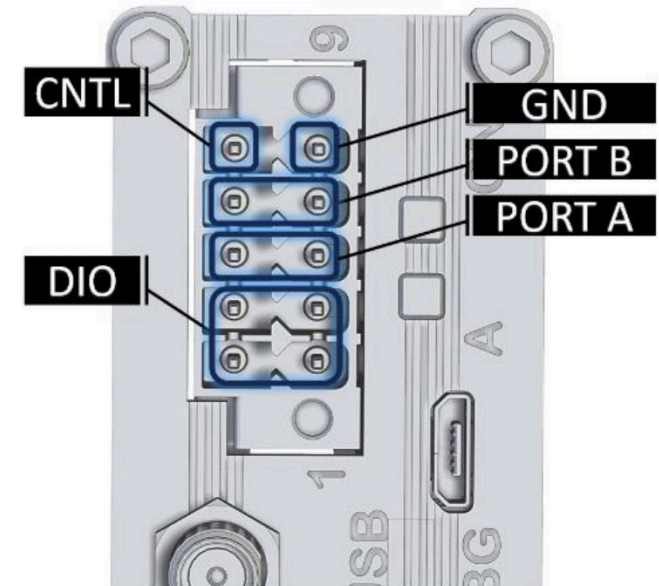

ABOUT

1.3 I/O & PORTS

DIGITAL INPUT & OUTPUT

- Key characteristics:
- Designed for 24V PLC applications
 - Digital outputs maximal output current - 1A per channel
 - Digital inputs self-powered with current limit

Digital I/O Operating Conditions

Parameter	Description	Min	Typ.	Max	Unit
VDC	External power supply voltage	6	24	30	V
VIN _{TLH}	Low to High input voltage		9.4	11	V
VIN _{THL}	High to Low input voltage	5	7.5		V
VIN _{HYST}	Input trigger hysteresis	1.2		2.6	V
IO _{UT}	Maximum output current per channel			1	A

Digital output wiring example

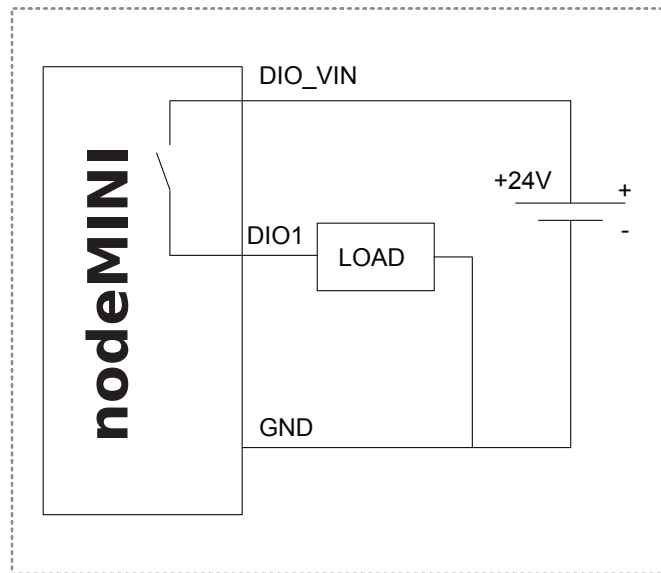

Digital input wiring example

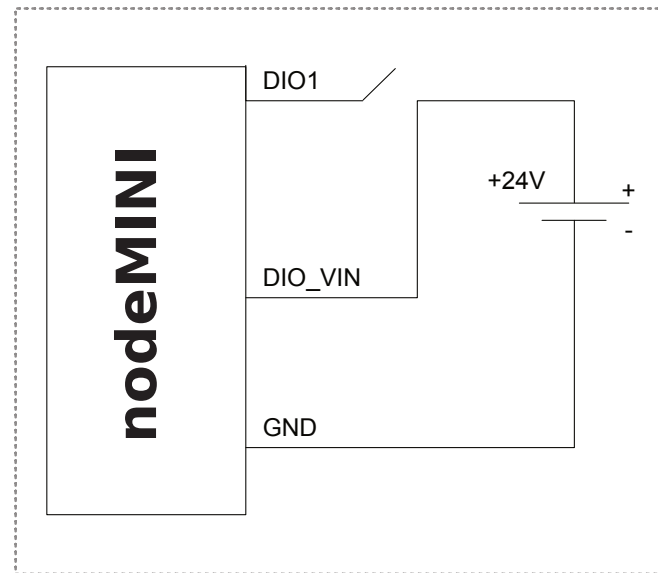

ABOUT

1. 4 REMOTE POWER

Warning:

Connecting the Remote Power Button pinout to DC voltage may damage the device.

Only connect the input pin to GND via contact switch.

REMOTE POWER CNTL INPUT

A remote power button can be connected to the CNTL pin on the terminal block. Pressing the button changes the power state of the system. Connect the button between the CNTL pin and common ground pin.

POWER BUTTON CONTROLS

Current State	Press	Resulting State
ON	Short	OFF (O/S controlled shutdown)
ON	Long	OFF (forced hardware shutdown)
OFF	Short	ON

TYPICAL CONNECTION SCHEMATIC

Typical wiring for remote pushbutton / relay contact. Do NOT feed CNTL with any external voltage.

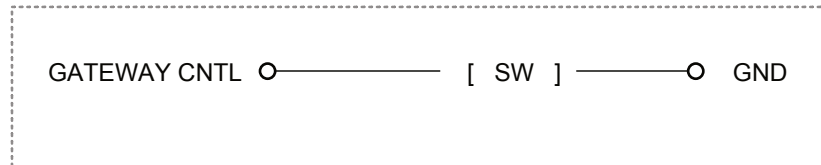

SETTING UP

2.1 SIM CARD INSTALLATION

Note:

The SIM card format used should be the nano-SIM.

The SIM card tray screw can be replaced with a secure TORX screw. Kindly refer to customer support for guidance.

INSTALLING THE SIM CARD

- Step 1: Disconnect the gateway from the power.
- Step 2: Unscrew the back plate of the nodeMINI gateway.
- Step 3: Place your SIM card in the tray. Refer to page 8 to see the SIM card orientation.
- Step 4: Secure back the tray into the gateway using a Philips screwdriver.
Ensure proper alignment with the housing.

SETTING UP

2. 2

LOGGING IN

For Security, after your first successful log in, you will be prompted to change your username & password.

Note: If you are using a SSH console:

The login username is:
root

The default password remains as:
node12345

STEP 3 of 5 - Plug in the Ethernet cable from ETH0 to your pc and power up the nodeMini.

STEP 4 of 5 - Launch your browser and enter address as <https://192.168.1.1>

STEP 5 of 5 - Log in.

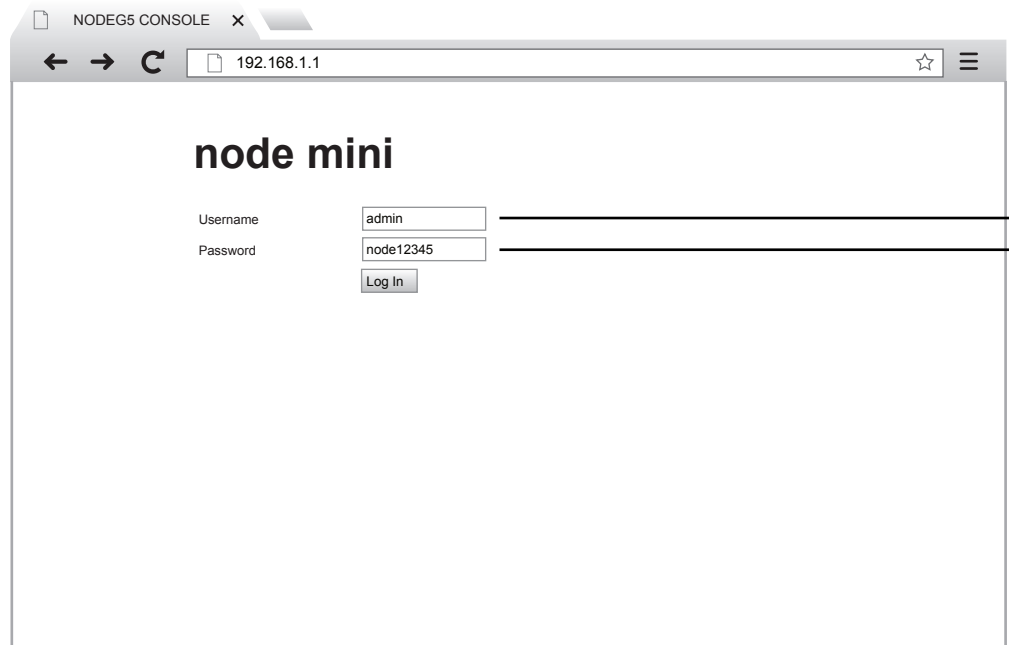

The default username is:
admin

The default password is:
node12345

node mini

3. 1 QUICK START

The Quick Start tab brings together all the settings you need to establish an immediate cellular connection in one page.

MENU OPTIONS Basic settings for nodeG5 Gateway for Cellular Internet Access

- Quick Start
- Cellular WAN
- Dynamic DNS
- Ethernet
- Wireless
- Serial / CAN

- IoT Hardware
- IoT Client

- Management
- System Status
- Logout

[nodemini User Manual.pdf](#)

LAN (eth0) Port Settings

LAN IP Address

 /

Cellular Settings

APN

User Name (PAP/CHAP only)

Password (PAP/CHAP only)

SIM PIN Code (If required only)

You can find resource PDF links in our web config to help guide you through the different setups.

Key in the IP Address for your nodeMINI gateway here.

To connect the nodeMINI to a cellular network the following information is required. You will be able to get them from your internet service provider.

Click on UPDATE to save your settings.

Password Management

Current Password

New Password

Reconfirm New Password

For security, please ensure you change to a new password.

node mini

MENU OPTIONS WAN and Cellular Settings

- Quick Start
- Cellular WAN**
- Dynamic DNS
- Ethernet
- Wireless
- Serial / CAN

- IoT Hardware
- IoT Client

- Management
- System Status
- Logout

Primary WAN Interface

Cellular ▼

Select your primary WAN interface from the options given. (Note that Wi-Fi is model dependent & you will need to complete the rest of your the settings in 'Wireless' tab.)

Cellular SIM Settings

APN

telstra.internet

Dial Number

*99#

User Name (PAP/CHAP only)

Password (PAP/CHAP only)

SIM PIN Code (If required only)

Service

LTE_UMTS Preferred ▼

Assigned DNS

8.8.8.8

NetMgr WWAN Connect Timeout

3

To connect the nodeMINI to a cellular network the following information is required. You will be able to get them from your internet service provider.

If you will like to override your network assigned DNS, you can input your own address here. Otherwise leave it blank.

Set the amount of minutes before the system does a reboot (0 = never)

Advanced Settings

Enable Reboot on PING failure

Disabled ▼

To ensure reliable connectivity you can choose to PING an external IP address.

PING Remote Host

8.8.8.8

Add in a test IP address (i.e. Google at 8.8.8.8)

PING Interval

5

Input the PING interval (in seconds) & number of retries made before the system reboots.

PING Retries

5

Update

When you have completed your settings on this page, click 'Update' to save them.

node mini

3. 3 DYNAMIC DNS

The Dynamic DNS feature helps to keep a standard domain name pointed to the nodeMINI even if it is assigned IP changes during a reboot/reconnection.

WHAT YOU'LL NEED

1. A data sim card with a public IP [You can check this with your operator.]
2. An account with a dynamic DNS service provider like dyndns2, easydns or changeip

MENU OPTIONS

- Quick Start
- Cellular WAN
- Dynamic DNS**
- Ethernet
- Wireless
- Serial / CAN

- IoT Hardware
- IoT Client

- Management
- System Status
- Logout

Dynamic DNS Settings

- Enable DDNS Client
- Protocol Name [web]
- Device Hostname URL
- Username
- Password

ENABLED ▾

dyndns2

demo.dyndns.org

your_username

UPDATE ConfigDDClient

Enable or Disable the DYNDNS service.

Enter in the DYNDNS service you have registered with.

Enter in the FQDN (fully qualified domain name) of your host at DDNS provider.

Key in your DYNDNS Service Username & Password.

Click 'Update' to save your settings. Then click 'ConfigDDClient' to configure DNS services. The nodeG6 will connect to your account and point the domain to your IPV4 address after you reboot.

In the above example, you will be able to access your nodeMINI using the domain name "demo.dyndns.org" on any regular browser.

node mini

3. 4 ETHERNET SETTINGS

MENU OPTIONS

- Quick Start
- Cellular WAN
- Dynamic DNS
- Ethernet**
- Wireless
- Serial / CAN
- IoT Hardware
- IoT Client
- Management
- System Status
- Logout

Ethernet Settings

eth0 (LAN) IP Address

 /

DHCP Enable

DHCP Start

 e.g. xxx.xxx.xxx Start

DHCP Limit

 Limit no. of IPs to assign

Set up the IP Address of your LAN port.

Enable the nodeMINI to automatically assign IP addresses to your connected LAN devices.

This would be the starting address for connected devices. For the example here, the first connected device will be assigned the address of 192.168.1.10

This will limit the number of connected devices. For this example the last connected device will be assigned 192.168.1.20

Once you have completed your settings click to save.

node mini

3. 5 WIRELESS SETTINGS

MENU OPTIONS Wireless Settings

- Quick Start
- Cellular WAN
- Dynamic DNS
- Ethernet
- Wireless**
- Serial / CAN

- IoT Hardware
- IoT Client

- Management
- System Status
- Logout

Wireless Mode

Disabled ▼

Settings for **'Infrastructure Mode'** : connects to your wi-fi router for internet access (WAN)

SSID

ssid

Security Type

WPA-PSK ▼

Password

IP Address

192.168.1.1 / 24

Router IP

Settings for **'Access Point Mode'** : connection point for your wi-fi enabled IoT devices

SSID

ssid

Security Type

WPA-PSK ▼

Password

IP Address for AP mode

100.10.10.1 / 24

Update

Select to enable (Note that Wi-Fi is model dependent.)

Key in the SSID of your wi-fi router.

Input the security settings to connect to your router.

Key in the IP address for your nodeMINI, or leave this blank to let it be assigned via DHCP.

Create a SSID for your nodeMINI access point.

Input the security settings to authenticate a connection with devices.

Key in the IP address for your nodeMINI as access point.

When you have completed your settings on this page, click 'Update' to save them.

node mini

3.6
SERIAL, CAN & I/O
SETTINGS

MENU OPTIONS

- Quick Start
- Cellular WAN
- Dynamic DNS
- Ethernet
- Wireless
- Serial / CAN**
- IoT Hardware
- IoT Client

- Management
- System Status
- Logout

Serial / CAN Settings

Serial Port A Parameters (RS485)

Speed E.g. 9600, 19200, 38400, 57600, 115200

Data Bits E.g. 7, 8

Parity

Stop Bits



Match the settings with your attached serial devices to the respective port (see wiring diagram on the previous page).

CAN Port Parameter

CAN0 Baudrate (default) E.g. 50000, 100000, 125000, 250000, 500000, 1000000

Match the settings with your attached CAN devices to the respective port (see wiring diagram on the previous page).

Click on 'Update' to save your settings.

node mini

3.7 IOT HARDWARE

MENU OPTIONS

- Quick Start
- Cellular WAN
- Dynamic DNS
- Ethernet
- Wireless
- Serial / CAN

IoT Hardware

- IoT Client
- Management
- System Status
- Logout

IOT Hardware Setup

Modbus data mode	<input type="text" value="Enabled"/>
CAN-bus data mode	<input type="text" value="J1939 mode"/>
GPS Position mode	<input type="text" value="Disabled"/>
Bluetooth: Power	<input type="text" value="OFF"/>
Event Drop Type	<input type="text" value="Disabled"/>
Poll Period	<input type="text" value="15"/> secs
Poll Time Out	<input type="text" value="5"/> secs
Query Pause	<input type="text" value="0.1"/> secs
Time Stamp Offset	<input type="text" value="0"/> hours (eg -2.5 or +8)

Diagnostics

Enable IoT HW log (for DEBUG/TEST only)	<input type="text" value="Disabled"/>
	<input type="button" value="UPDATE"/>

Click to enable Modbus mode

Choose 'Query mode' to send request packet & read response values. Choose 'Read mode' when slaves auto report their status/values. J1939 users will also need to choose that CAN bus option here.

GPS is cellular modem dependant. Select to activate tracking.

Enable the Bluetooth option here. Note that this feature is model dependant.

Select the time interval of reading data events of the iotasset listing. If you wish, have a different polling period for different assets, refer to our web FAQ to set your iotasset.json configuration.

The timeout specifies the time period to accept responses after each network request. Ensure adequate spacing that takes into account network traffic and latency.

If you require a pause between separate poll queries, set it here.

Set your local timezone for event timestamp.

Generate a Modbus, CAN or GPS log file for debug or testing.

Update and reboot the nodeMINI

CONFIGURATION

node mini

3.7 IOT HARDWARE

Methods to upload the `iotasset.json` config files:

1. via this browser/PC using the 'upload button'
2. via files transfer using SCP/PuTTY
3. via USB drive /user folder in the Management tab

IMPORTANT ::

Please upload the following settings via the **Management** tab.

`iotasset.json` with hardware device settings (e.g. Modbus addresses)

`connstr.txt` with Azure settings (e.g. Azure IoT device id token)

MENU OPTIONS

Quick Start
Cellular WAN
Dynamic DNS
Ethernet
Wireless
Serial / CAN

IoT Hardware IoT Client

Management
System Status
Logout

IOT Hardware Setup

Configuration: `iotasset.json`

Check File :: [Check iotasset.json](#)

UPLOAD IOTASSET.JSON FILE

DATA SNAPSHOT :: [Show Data](#)

DELETE DATA

Warning : Will delete all user sensor data

Click to see the current configurations file in a new web page.

Ensure that the gateway HTTPS console must be accessible before proceeding with these steps.

1. Click on the 'UPDATE IOTASSET.JSON FILE' button.
2. In the new window, click on 'CHOOSE FILE' & select the updated file from your local folder.
3. Click 'UPLOAD FILE'
4. After these settings are updated, reboot the nodeMINI to implement the changes.

If the update failed, check that the connection to the gateway is stable. Or else please contact support@amplified.com.au

Delete all JSON data.

Show a snapshot of the current data.

node mini

3.8 IOT CLIENT

MENU OPTIONS

- Quick Start
- Cellular WAN
- Dynamic DNS
- Ethernet
- Wireless
- Serial / CAN

IoT Hardware
IoT Client

- Management
- System Status
- Logout

IOT Client Setup

Client Setup :: Azure IoT

nodemini Azure IoT Quick Start Guide [web pdf](#)

Device ID

Client Type

Provisioning Host

ID Scope

SAS Private Key

Enable Client

Enter the Device ID you use to set up your Microsoft Azure IoT Account.

Select if you are connecting to Azure IoT Hub or IoT Central.

Enter the endpoint/host for sending the data. By default this is set to 'global.azure-devices-provisioning.net'

Enter in the ID scope assigned to your Azure device provisioning service.

Enter the SAS private key that is generated using your device connection string.

Select to Enable the Azure IoT Client

Client Setup :: AWS IoT

nodemini AWS IoT Quick Start Guide [web pdf](#)

Client ID

Thing Name

Topic

AWS Endpoint

AWS Port

Enable Client

Enter the Client ID, Thing Name, Topic, Endpoint & AWS Port as per the settings in your AWS account

Select to Enable the AWS IoT Client

node mini

3.8 IOT CLIENT

MENU OPTIONS

- Quick Start
- Cellular WAN
- Dynamic DNS
- Ethernet
- Wireless
- Serial / CAN

IoT Hardware
IoT Client

- Management
- System Status
- Logout

IOT Client Setup

Client Setup :: Ubidots

nodemini ubidots IoT Quick Start Guide [web pdf](#)

Device Token

Device Name

Enable Client ▼

Enter the Device Token & Name as per the settings in your Ubidots account

Select to Enable the Ubidots IoT Client

Client Setup :: MQTT/ Google Cloud

nodemini MQTT IoT Quick Start Guide [web pdf](#)

Broker Host

Message Topic

Host Port

Username for port 1883

Password for port 1883

Enable Client ▼

Enter the MQTT Broker IP that you want to connect to

And your Topic as per the settings in your Broker/ to describe your data set

And the Broker Port details as per the settings in your MQTT Broker

Enable the nodeMINI as a MQTT IoT Gateway

Diagnostics

Enable IoT Client Log (for DEBUG/TEST only) ▼ [Client Log File](#)

Enable and download a log for debug or testing

CONFIGURATION

3. 10 MANAGEMENT

Note that from the internet, the nodeMINI can only be accessed via HTTPS (secure) to ensure all data between user and nodeMINI web configuration page is encrypted.

We give our clients the choice to install their own signed certificate (e.g. Verisign or Digicert) via SSH to nodeMINI console. Since there is no packaged signed SSL certificate in each nodeMINI, a complaint of error might be issued from the browser. Note that this does not affect the secure encryption of data to configure the nodeMINI via HTTPS.

node mini

MENU OPTIONS System Management

- Quick Start
- Cellular WAN
- Dynamic DNS
- Ethernet
- Wireless
- Serial / CAN

- IoT Hardware
- IoT Client

- Management**
- System Status
- Logout

[nodemini User Manual.pdf](#)

Web Login Username

Enable https access from WAN

Enable Secure Shell (SSH)

Enable System Log

System Time reference

Set Up RTC (hardware clock)

Password Management

Current Password

New Password

Reconfirm New Password

This login name is only used for web. If you are using SSH, always log in as 'root'.

Click to enable remote https access via WAN port 443. Note that non secure https access via WAN is not allowed.

Disabled by default. If enabled it will provide root access using the default login details on page

If enabled you can download/view the log page from the 'System status page.

Choose a system time source reference as ntp (online time service) or rtc (on-board battery back hardware clock).

Click to update hardware clock using the current system

For security, please do not use default password for your deployed unit.

Passwords are never stored directly but as a hash string to increase device security.

node mini

MENU OPTIONS System Management

- Quick Start
- Cellular WAN
- Dynamic DNS
- Ethernet
- Wireless
- Serial / CAN

- IoT Hardware
- IoT Client

- Management**
- System Status
- Logout

Configuration Parameters Management

Please insert usb drive labelled 'nodemini'.
Configuration file (config.db) backup & restore

Download config.db from nodemini

Upload config.db to nodemini

User Configuration and Scripts Management

Please insert a USB drive labelled 'nodemini'.
Files (e.g. iotasset.json, firewall.user, user.lua, user.py or connstr.txt) must be in the /user folder.

Download /user to nodemini

Execute user.lua Script

Delete User files

Execute user.py Script

To allow 'cloning' of parameter settings to multiple nodemini in deployment we utilise USB flash drives.

1. Format a USB thumb-drive (e.g. NODE32) and label it 'nodemini'
2. After the nodeMINI is powered up insert the thumb-drive into an available USB port.
3. Click 'Download config.db from nodeMINI', wait 5 seconds & remove thumb-drive
4. Insert the thumb-drive into new nodeMINI and click 'Upload config.db to nodemini', wait 5 seconds and remove thumb-drive
5. Check in new nodeMINI that parameters from other nodeMINI has been copied over

To input your own LUA or Python program:

1. Write your LUA or Python program and name it as 'user.lua' or 'user.py'
2. Save the program in /user folder in your thumb-drive (drive labelled 'nodemini')
3. Insert the thumb-drive into your nodeMINI
4. Click 'Download /user to nodemini', wait 5 seconds and remove the thumb-drive
5. You can click 'Execute Program' to test your program

Your program will automatically be executed after complete boot-up of the nodeMINI.

node mini

MENU OPTIONS System Management

Quick Start
Cellular WAN
Dynamic DNS
Ethernet
Wireless
Serial / CAN

IoT Hardware
IoT Client

Management
System Status
Logout

Firmware Management

Install Firmware Patch [Patch Guide.pdf]

System Recovery Management

Factory Settings

Reboot System

Ensure that the gateway HTTPS console must be accessible before proceeding with this steps.

1. Click on the 'UPDATE FIRMWARE' button.
2. In the new window, click on 'CHOOSE FILE' and select from your local folder the specific firmware update .zip file. (Please check with support@amplified.com.au for any assistance).
3. Click 'UPLOAD FIRMWARE PATCH'. If the firmware has been successful you will get the following message:

"RESULT: The firmware update has been applied"

4. After closing the page, you will need to log in again for security purposes.

If the update failed, check that the connection to the gateway is stable. Or else please contact support@amplified.com.au

Click 'Reboot' to soft reset the nodeMINI device.

Click 'Factory Settings' to revert all parameters to factory default.

node mini

3. 11 SYSTEM STATUS

MENU OPTIONS	System Status	
Quick Start	Main	
Cellular WAN	Firmware Revision	fw_mini_2.0beta
Dynamic DNS	Serial Number	124111130000006
Ethernet	Kernel Version	6.1.55-1.0
Wireless	System Date & Time	Thur Apr 8 02:41:16 UTC 2025
Serial / CAN	Upload and CPU Load (1,5,15m)	02:41:16 up 16 min, 1 user, load average: 0.25, 0.22, 0.13
IoT Hardware	CPU Temperature	39 * C
IoT Client		

Management
System Status
Logout

Cellular WAN	
Modem firmware	25.30.606 1 [Jun 07 2021 06
IMEI	--
USIM IMSI	502181121133668
USIM ICCID	8960181171211336711
Modem State	connected
Interface	wwan0
SIM APN	telstra.internet
IP4 address	21.173.254.22
Operator Name	U Mobile
Roam Status:	home
Service Mode:	lte
Cellular Signal Quality (CSQ):	63%
Received Signal Strength Indicator (RSSI):	63%
Reference Signal Received Power (RSRP):	63%
Reference Signal Received Quality (RSRQ):	63%
Signal-to-Interface+Noise Ratio (SINR):	63%
Cellular Data (since bootup)	RX packets 30 bytes 3286 (3.2 KIB) TX packets 42 bytes 3994 (3.9 KIB)

System Log: [System Log File](#)

Diagnostics [Diagnostics Output File](#)

Run a system diagnostic test

CONTACT US

.....
TECHNICAL
SUPPORT: SUPPORT@AMPLIFIED.COM.AU

SALES: SALES@AMPLIFIED.COM.AU

.....
WEBSITE AMPLIFIED.COM.AU

.....
ADDRESS Amplified Engineering Pty Ltd
 Unit 3, 2A Brodie Hall Drive
 Bentley WA 6102, Australia
 ABN 44127163035

